

RANCHO SANTIAGO COMMUNITY COLLEGE DISTRICT



ADDENDUM NO. 1

Bid #1419 Barrier Removal Building D Multi-user and Single-user Restrooms Renovation
at
Santiago Canyon College

Address: 8045 E. Chapman Ave., Orange, CA 92869

Project ID #2742,
DSA #04-120549 (Multi-user Restrooms) & 04-120550 (Single-user Restrooms)

May 4, 2022

**Owner:
Rancho Santiago Community College District
2323 North Broadway, Room 112
Santa Ana, California 92706**

RECEIPT OF THIS ADDENDUM MUST BE ACKNOWLEDGED ON BID FORM WHEN
SUBMITTED

The following changes, additions, deletions or corrections shall become a part of the Contract Documents for the project named on the previous page and all other conditions shall remain the same. The Bidders shall be responsible for transmitting this information to all affected Subcontractors and Suppliers, prior to the closing of Bids. Prospective Bidders shall acknowledge receipt of all Addenda in the space provided on the Bid Proposal Form by the number (list every addenda). Failure to do so shall deem the Bid Proposal as non-responsive and subject the Bidder to disqualification.

Item No. AD 1-1: Construction Phasing Plan

Replace Construction Phasing Plan in Attachment E with the attached drawing, CPP#1.

Item No. AD 1-2: Temporary Partition Plan

Replace Temporary Construction Partition in Attachment G with the attached drawing, TPP#1.

Item No. AD 1-3: Construction Staging Plan

Add Construction Staging Plan. See attached drawing, CSP#1.

Item No. AD 1-4: Bid Documents, Part 2, Supplementary Conditions, pg. 104

Delete item b), i), of item article 9, entirely. Replace with:

Renovation work of the Multi-user Restrooms and Single-user Restrooms shall be substantially completed in two phases. Phase 1 includes renovation of two multi-user restrooms on second floor. Phase 2 includes renovation of two multi-user restrooms and two single-user restrooms on first floor. The contractor shall not occupy the project site areas before September 5, 2022. No construction or demolition work shall occur before September 5, 2022.

Item No. AD 1-5: Responses to RFIs

The following provides a response to the Bidder's Request for Information (RFI). See attached a total of six (6) RFI responses.

Enclosed:

RFIs 1 through 6

This is the end of Addendum No.1

RFI # 1

PRE-BID CLARIFICATION FORM

(Email this completed form to FacilitiesBid@rsccd.edu. See Instructions to Bidders.)

PROJECT NAME:	Barrier Removal Building D Multi-user and Single-user Restrooms Renovation at Santiago Canyon College		
PROJECT NUMBER:	2742	BID NUMBER:	1419
EMAIL TO: facilitiesbid@rsccd.edu			
DATE:	4/15/2022		
FROM:	Caliba Inc.	EMAIL:	bidding@calibainc.com
SPEC SECTION:		DRAWING NUMBER:	
REQUESTED CLARIFICATION:			
<p>What is the Engineer's estimate for this project? Please advise. Thank you.</p>			
RESPONSE TO CLARIFICATION:			
<p>The Architect's estimate for this project is between \$900,000.00 and \$950,000.00.</p> <p>Responded to by RSCCD.</p>			

Attach additional numbered sheets as necessary; however, only one (1) request shall be contained on each submitted form.

END OF DOCUMENT

RFI # 3

PRE-BID CLARIFICATION FORM

(Email this completed form to FacilitiesBid@rsccd.edu. See Instructions to Bidders.)

PROJECT NAME:	Barrier Removal Building D Multi-user and Single-user Restrooms Renovation at Santiago Canyon College		
PROJECT NUMBER:	2742	BID NUMBER:	1419
EMAIL TO: facilitiesbid@rsccd.edu			
DATE:	4/18/22		
FROM:	Golden Gate Construction	EMAIL:	davis.goldengate@gmail.com; sunny.goldengate@gmail.com;
SPEC SECTION:		DRAWING NUMBER:	
REQUESTED CLARIFICATION:			
4) Provide the existing Fire Alarm Panel Information with Mfg. & Model Number			
RESPONSE TO CLARIFICATION:			
The existing Fire Alarm Panel is a Notifier #NFS-640. Responded to by the Design Team.			

Attach additional numbered sheets as necessary; however, only one (1) request shall be contained on each submitted form.

END OF DOCUMENT

PRE-BID CLARIFICATION FORM

(Email this completed form to FacilitiesBid@rsccd.edu. See Instructions to Bidders.)

PROJECT NAME:	Barrier Removal Building D Multi-user and Single-user Restrooms Renovation at Santiago Canyon College		
PROJECT NUMBER:	2742	BID NUMBER:	1419
EMAIL TO: facilitiesbid@rsccd.edu			
DATE:	4/18/22		
FROM:	Golden Gate Construction	EMAIL:	davis.goldengate@gmail.com; sunny.goldengate@gmail.com;
SPEC SECTION:		DRAWING NUMBER:	
REQUESTED CLARIFICATION:			
5) Provide the existing Fire Alarm Monitoring Vendor's contact information.			
RESPONSE TO CLARIFICATION:			
The District is using Cosco Fire Protection, Inc. for maintenance, inspection, testing, and monitoring services. Contact Information: Mike McDade (724) 231-6796 1075 W. Lambert Rd. Brea, CA 92821 Responded to by RSCCD.			

Attach additional numbered sheets as necessary; however, only one (1) request shall be contained on each submitted form.

END OF DOCUMENT

RFI # 5

PRE-BID CLARIFICATION FORM

(Email this completed form to FacilitiesBid@rsccd.edu. See Instructions to Bidders.)

PROJECT NAME:	Barrier Removal Building D Multi-user and Single-user Restrooms Renovation at Santiago Canyon College		
PROJECT NUMBER:	2742	BID NUMBER:	1419
EMAIL TO: facilitiesbid@rsccd.edu			
DATE:	4/18/22		
FROM:	Golden Gate Construction	EMAIL:	davis.goldengate@gmail.com; sunny.goldengate@gmail.com;
SPEC SECTION:		DRAWING NUMBER:	
REQUESTED CLARIFICATION:			
6) Please Confirm the (N) Toilet Partitions would be Overhead Braced and Floor Anchored (Combination) per Plan A-900 and Spec. Section 10 21 13, para. 1.2.A			
RESPONSE TO CLARIFICATION:			
Multi User Restrooms - All new toilet partitions only to be connected overhead to the header per detail 16 and 17 on sheet A-900. Partitions are not floor anchored. Single User Restrooms - All new toilet stall partition to be overhead braced and floor anchored as shown on the plans. Responded to by the Design Team. See attached drawing, A-900. Responded to by RSCCD.			

Attach additional numbered sheets as necessary; however, only one (1) request shall be contained on each submitted form.

END OF DOCUMENT

Addendum #1

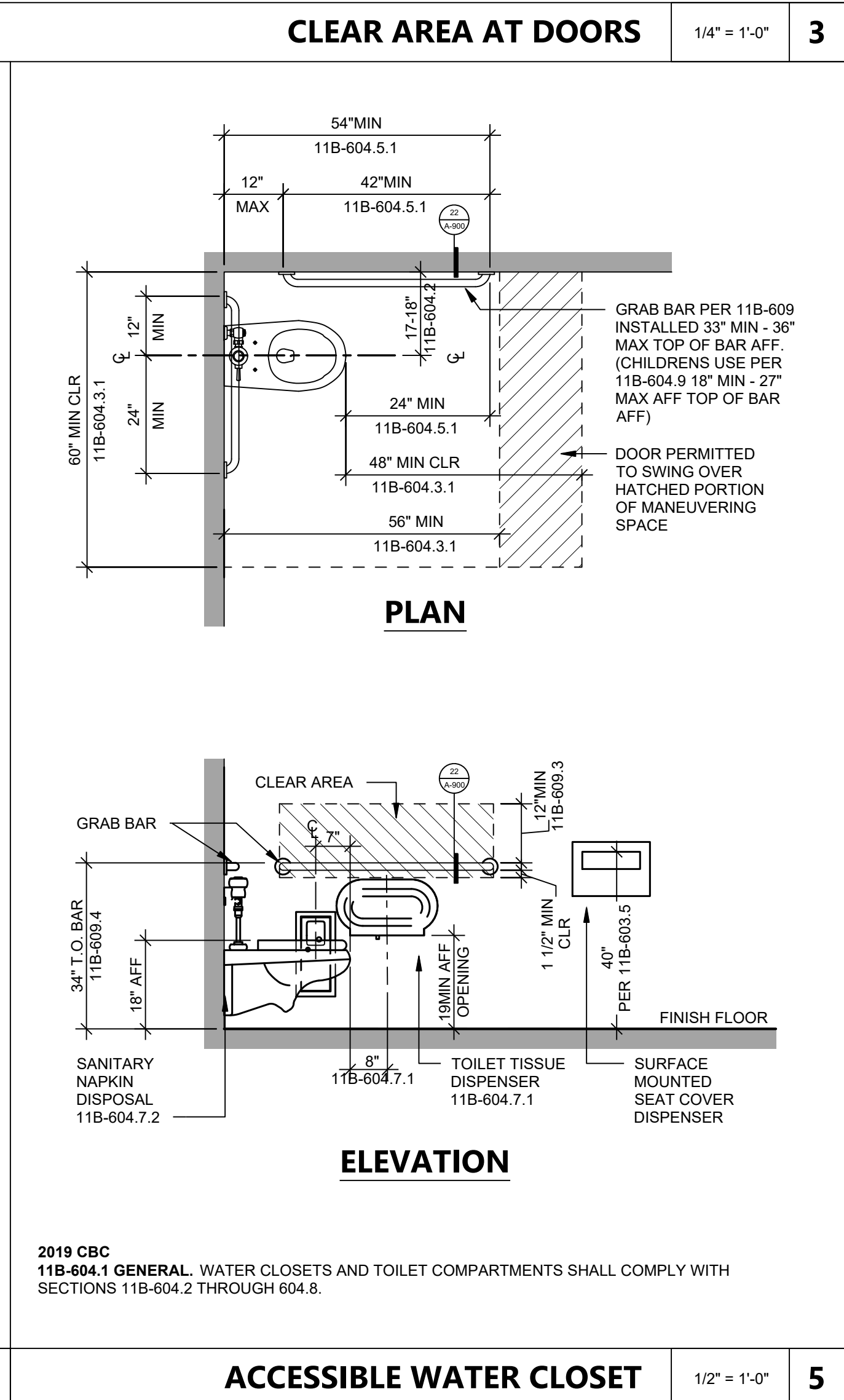
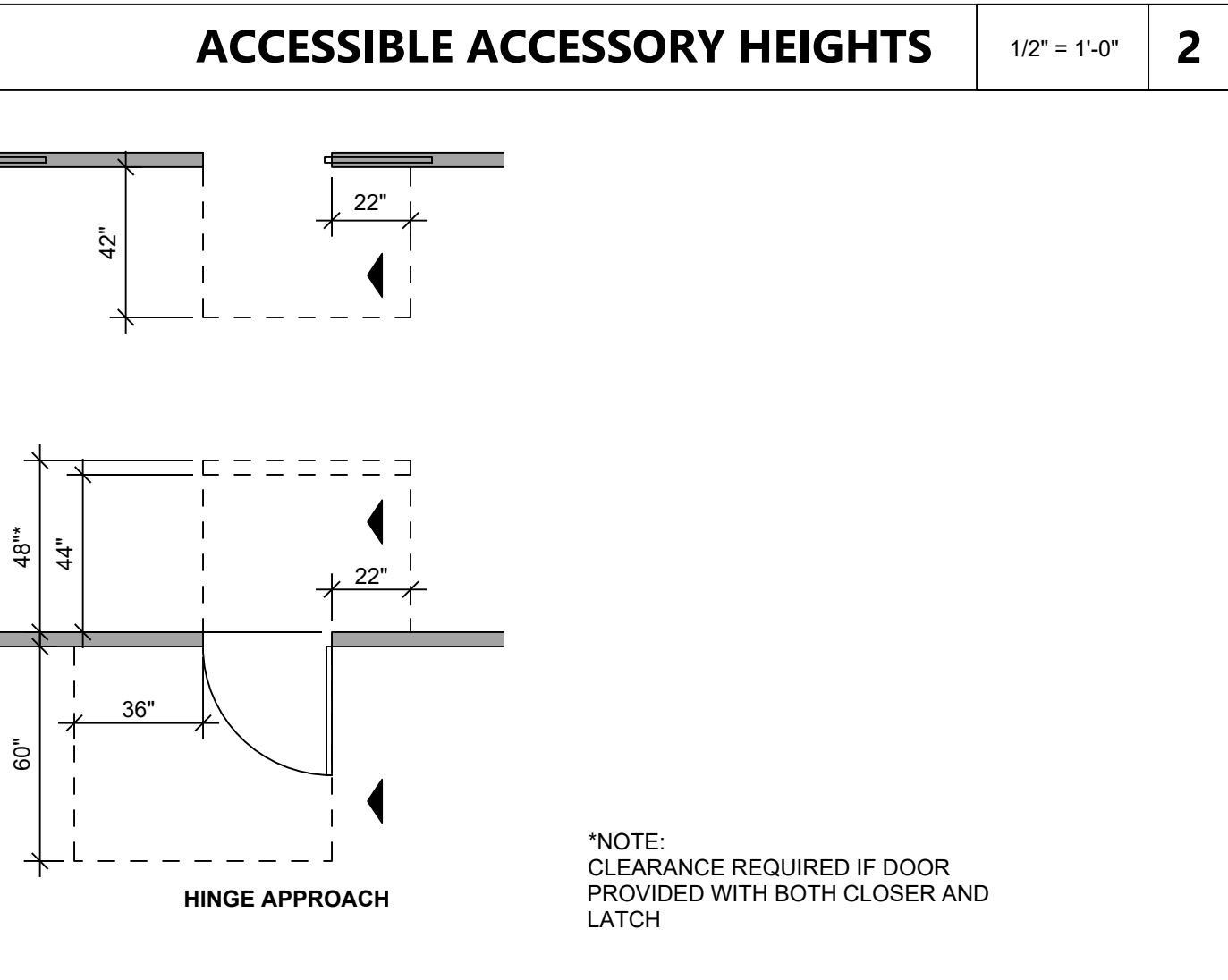
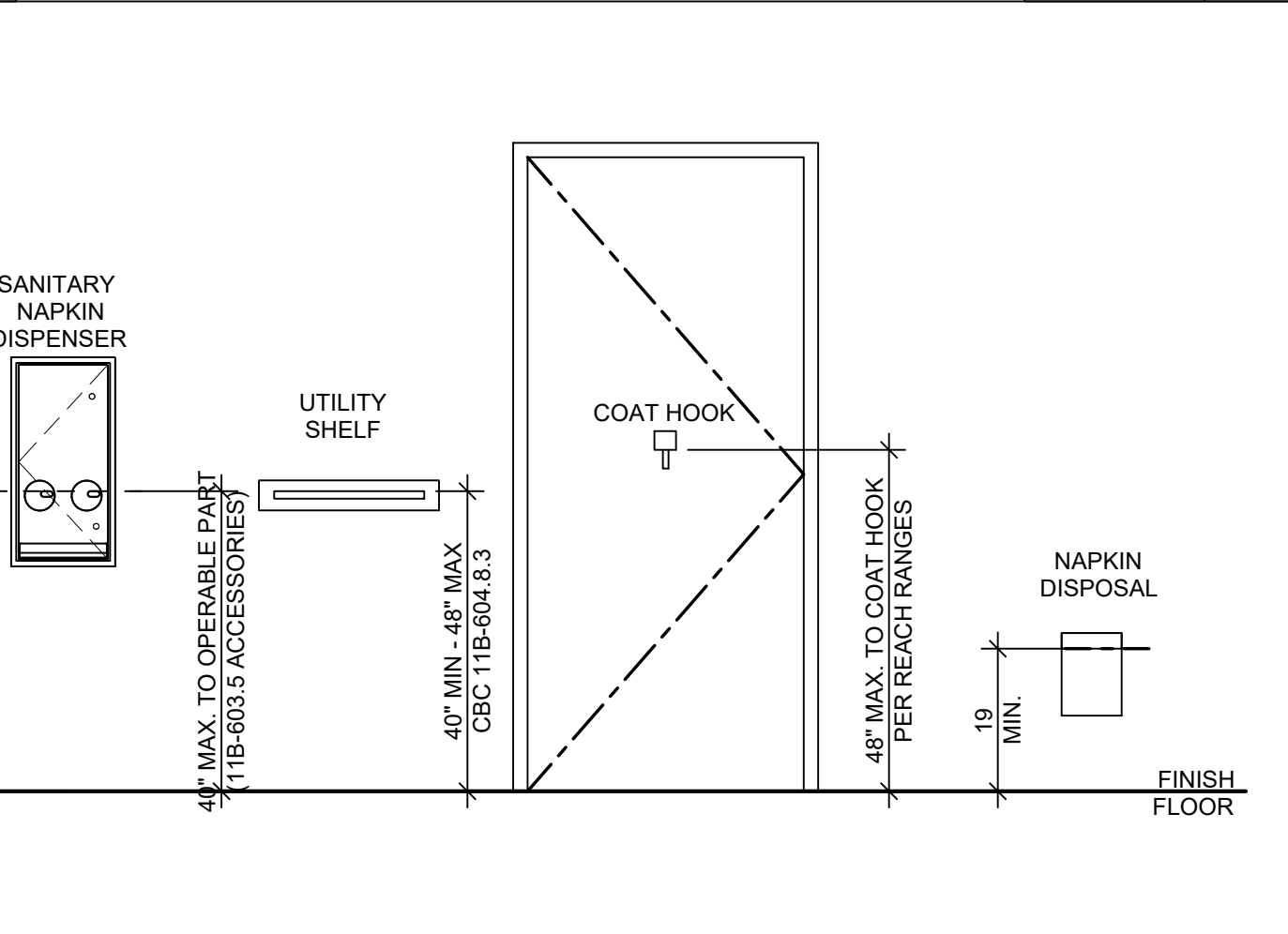
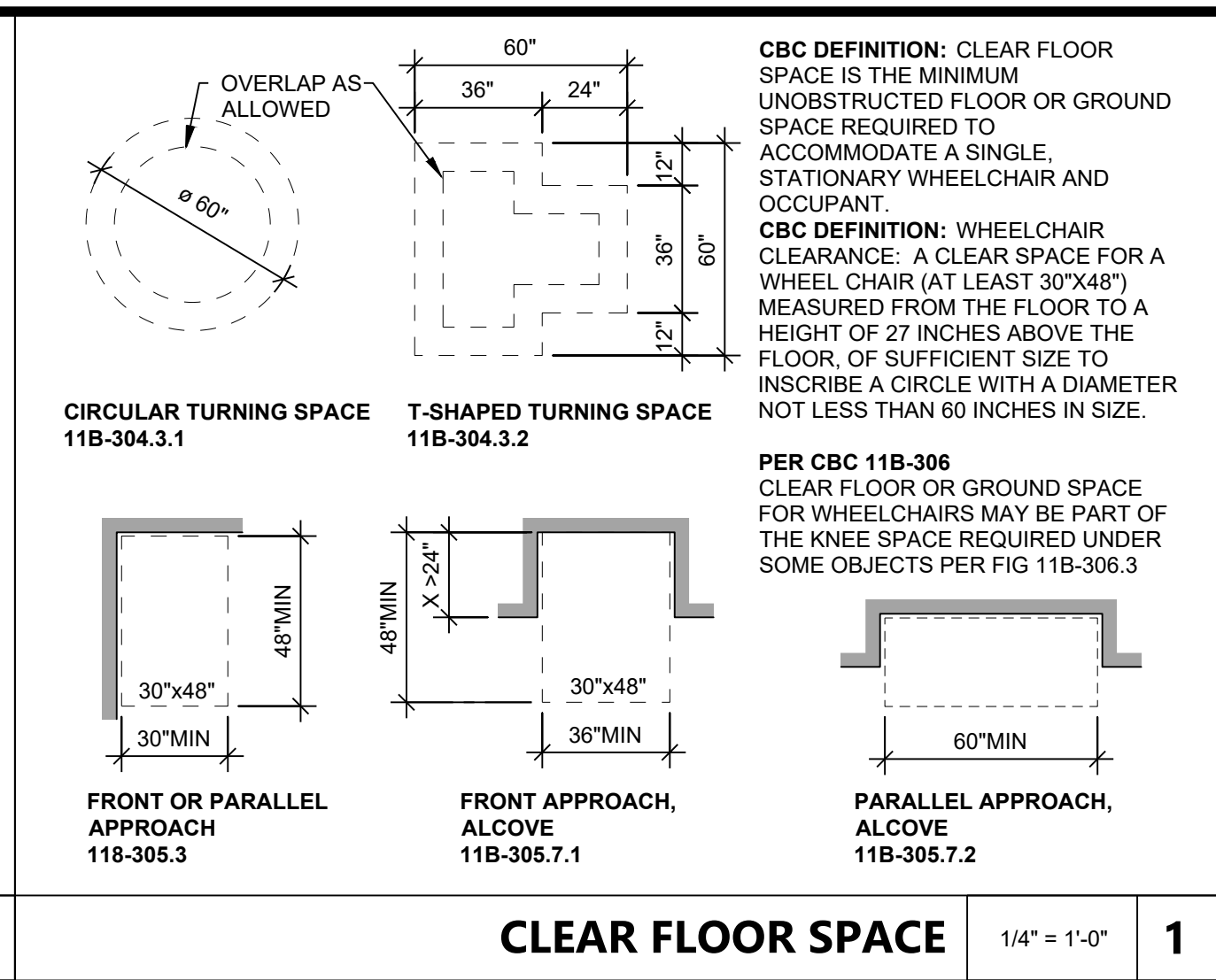
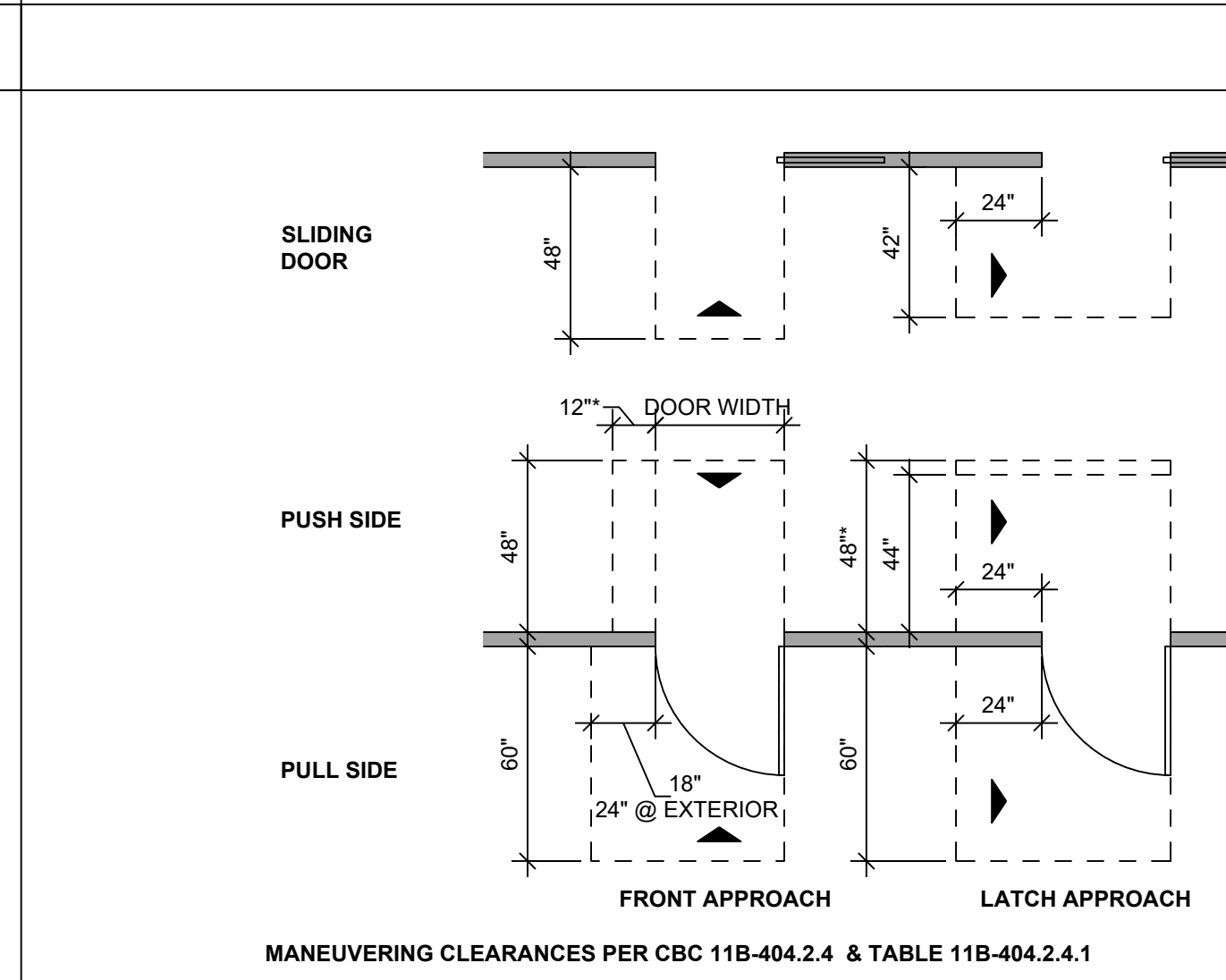
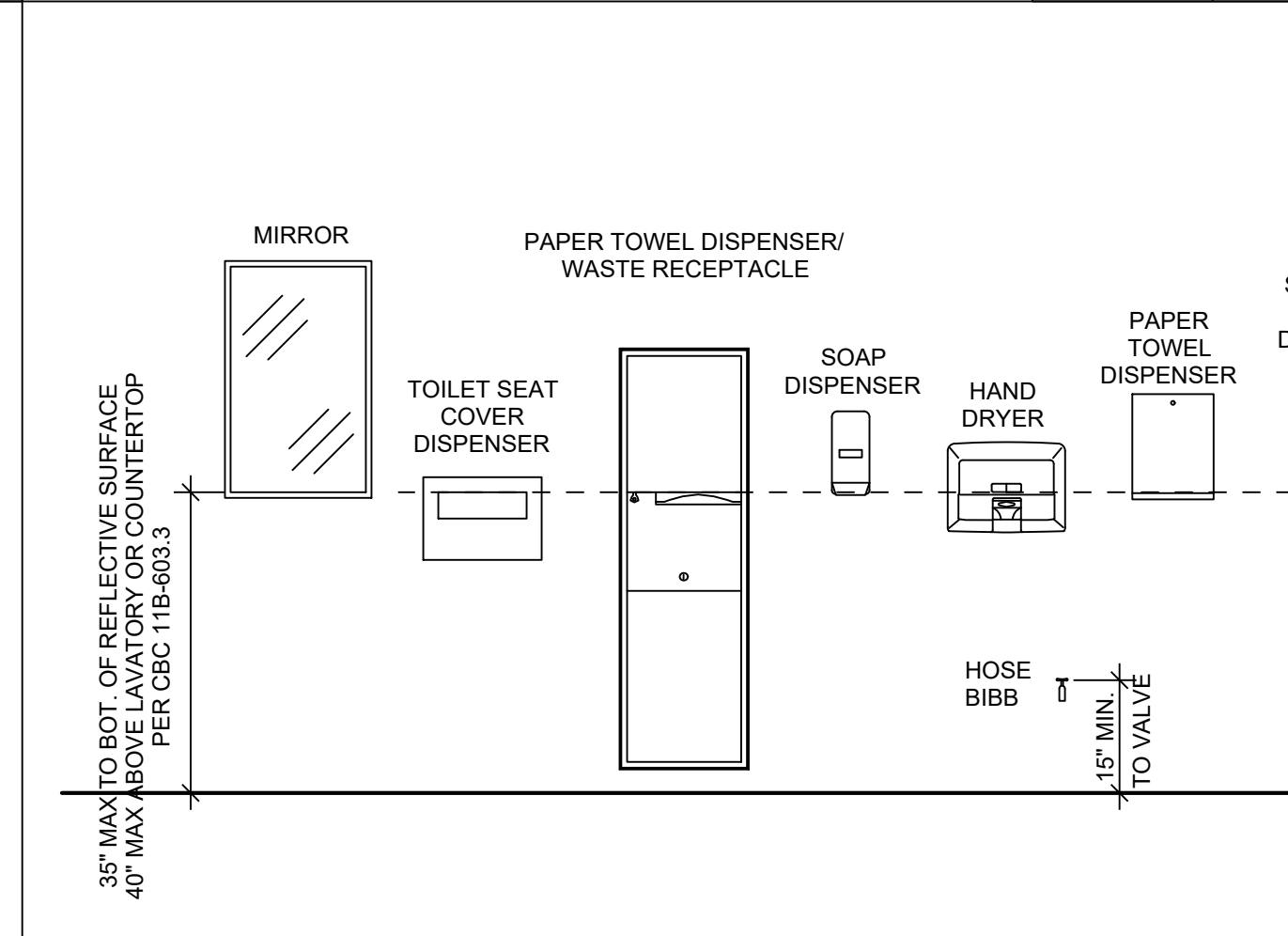
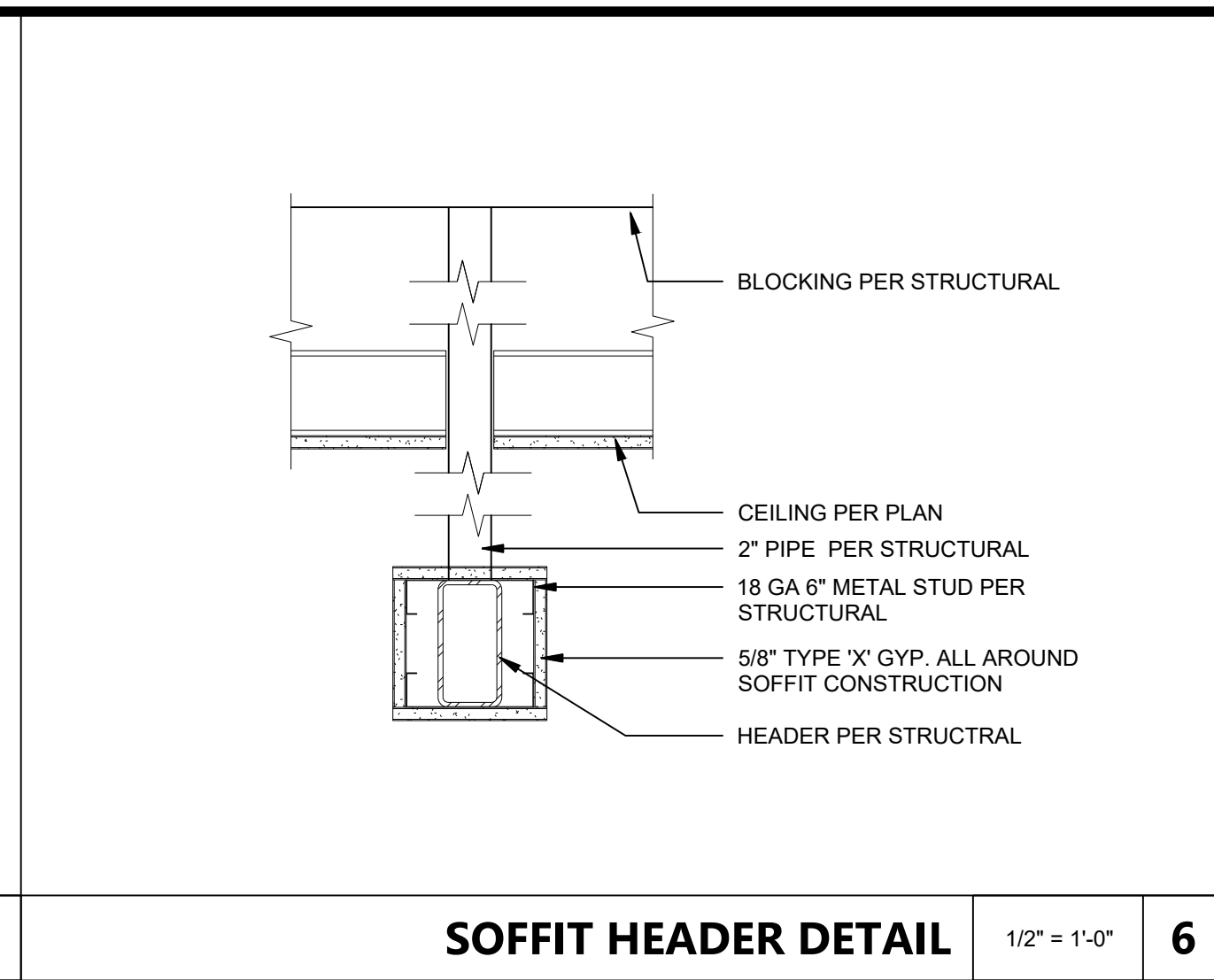
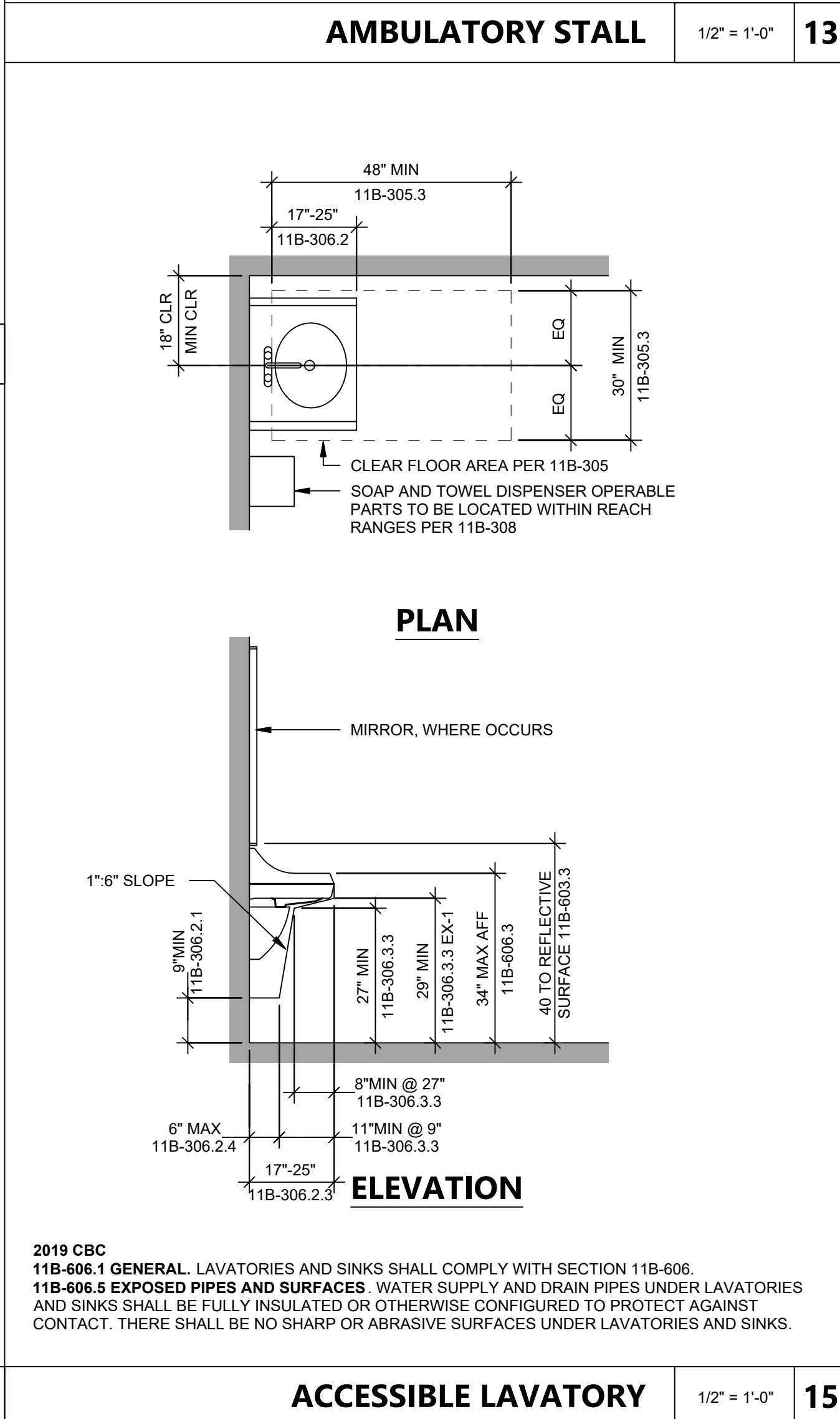
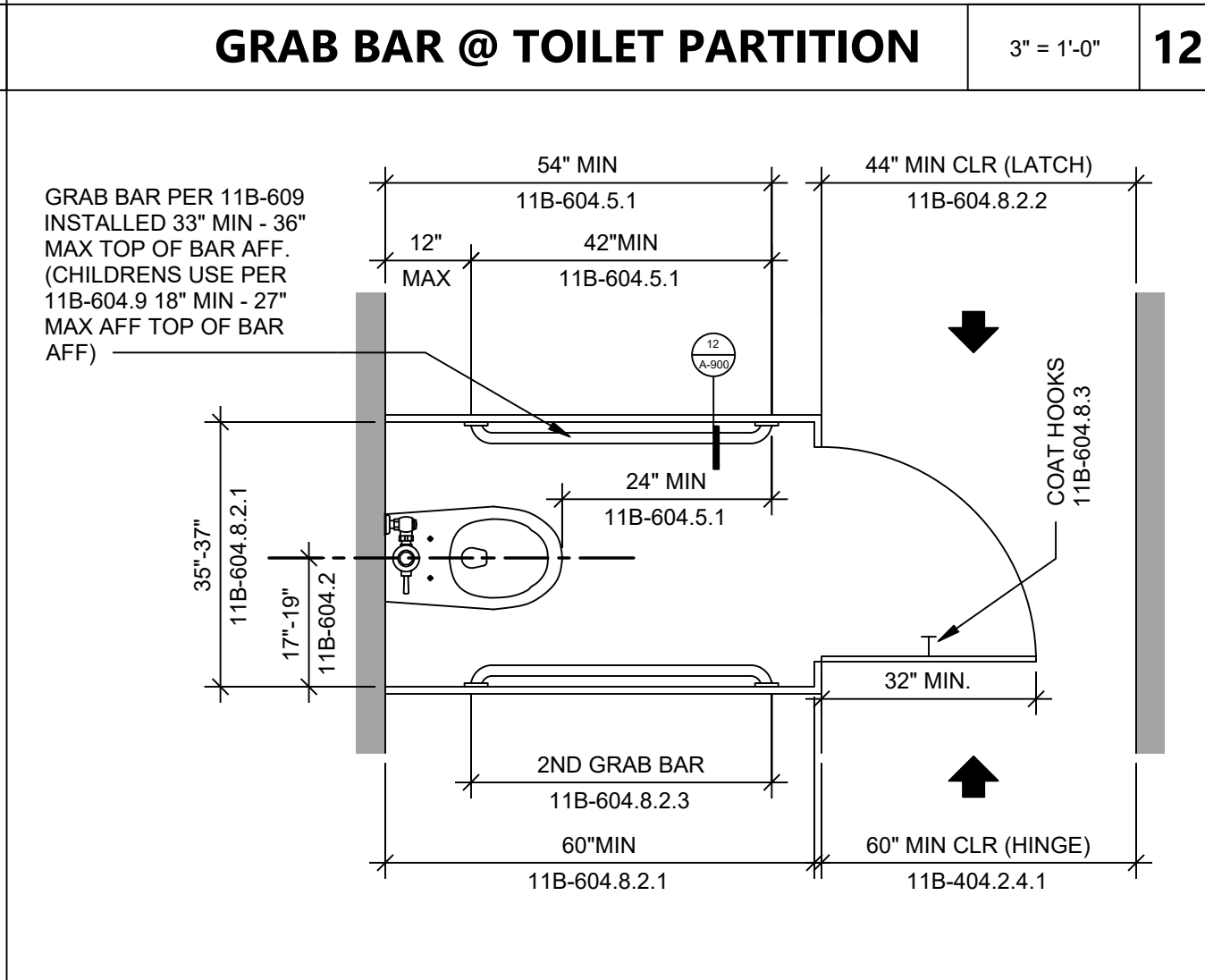
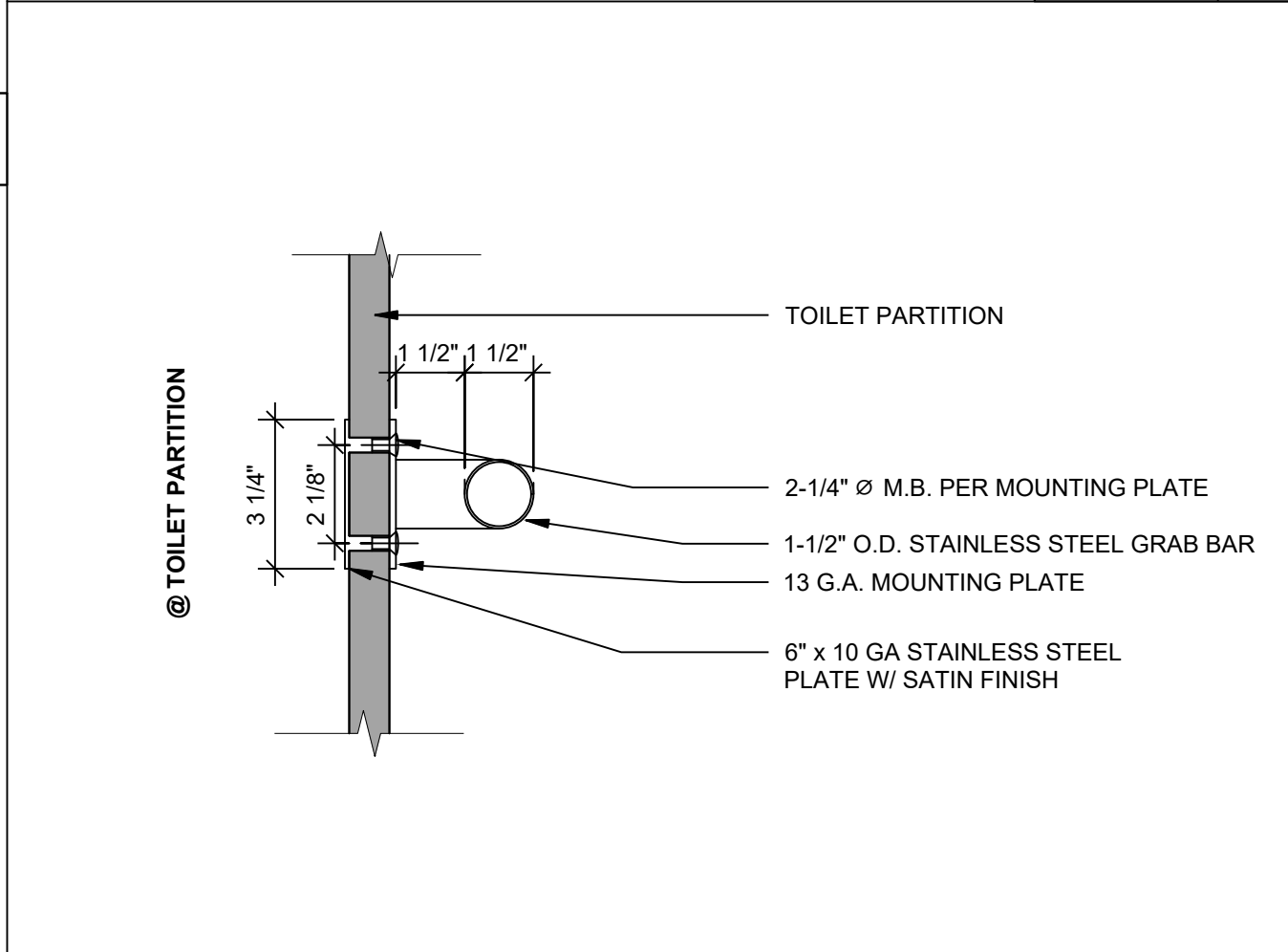
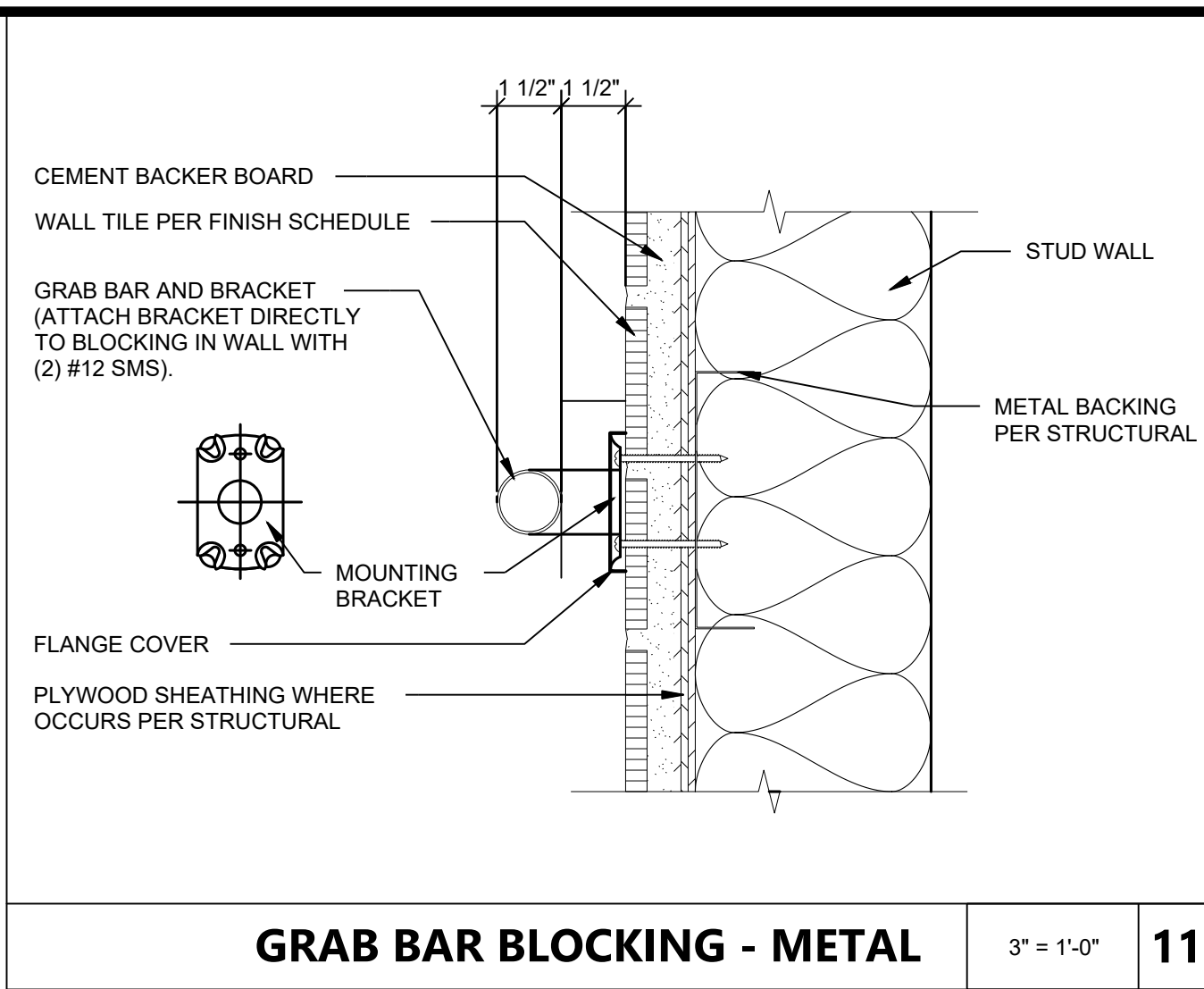
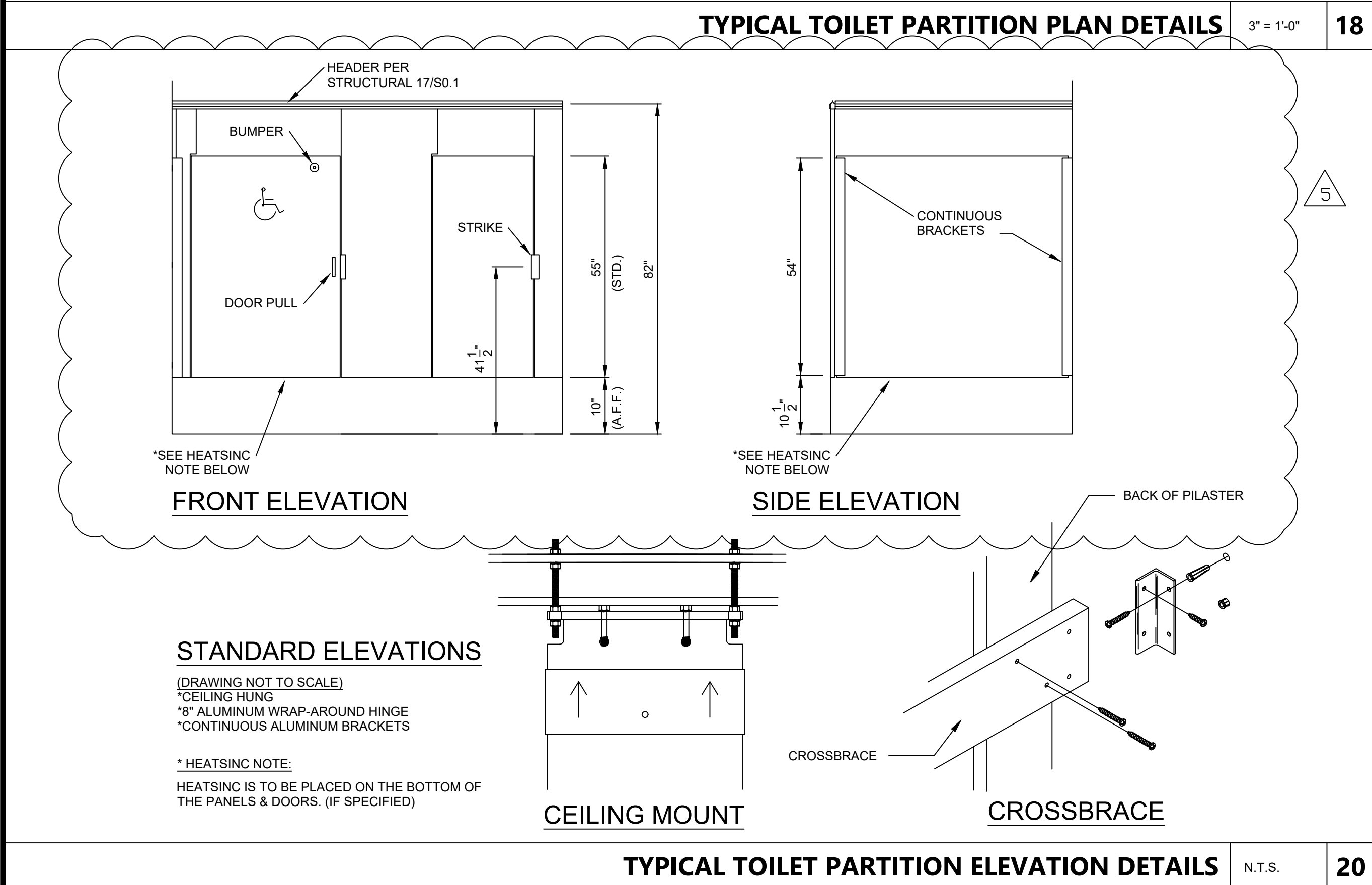
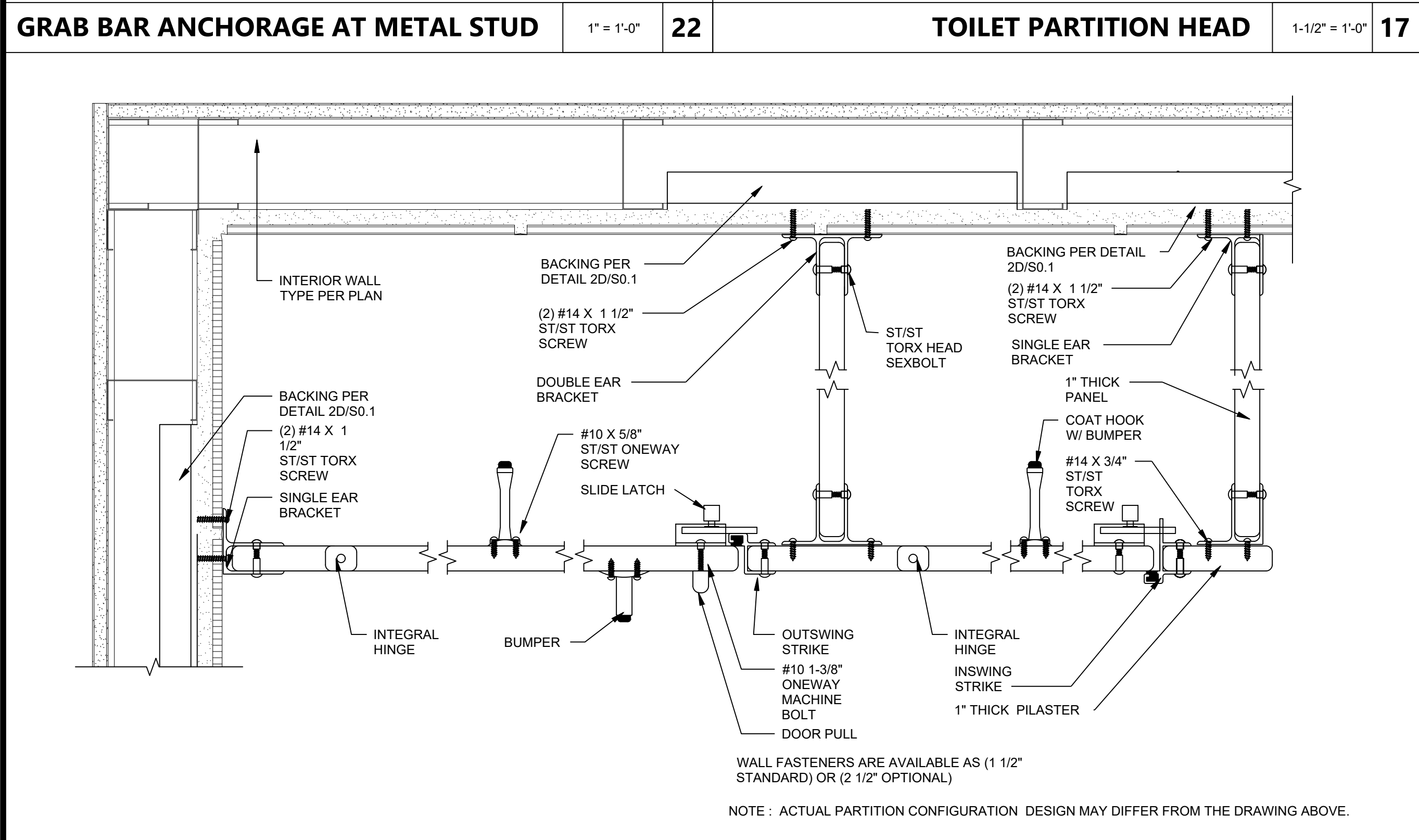
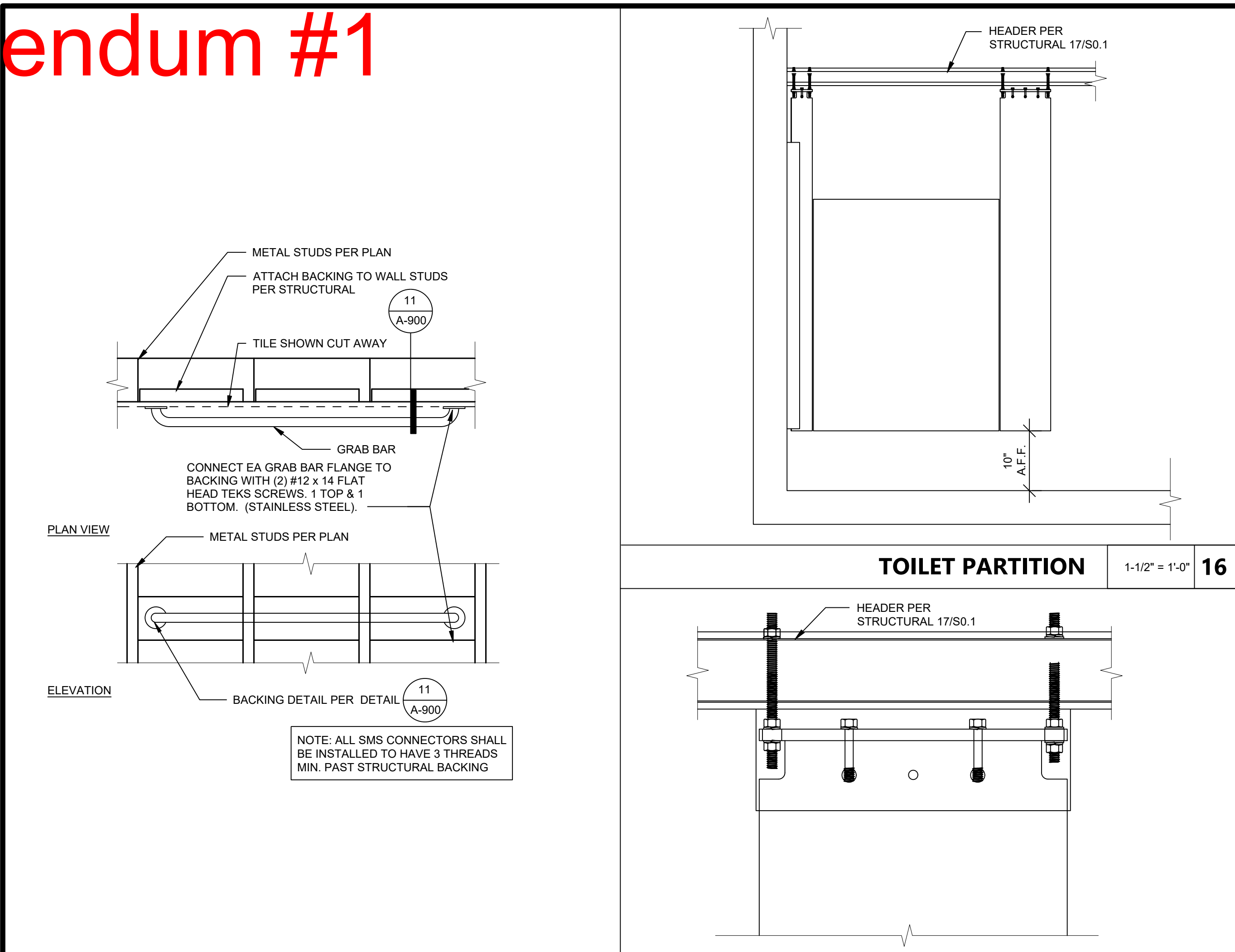

AGENCY APPROVAL

19.6 ARCHITECTS

250 E RINCON STREET, SUITE 108
CORONA, CA 92879
TEL (805) 963-1955

PROJECT TEAM

STRUCTURAL ENGINEER
T & B ENGINEERING, INC.
4434 Latham St. Suite 210
Tustin, CA 92780
Tel (949) 417-3903 x 104

MECHANICAL ENGINEER
POCOCK DESIGN SOLUTIONS
14451 Chambers Road, Suite 210
Tustin, CA 92780
Tel (949) 417-3903 x 106

PLUMBING ENGINEER
POCOCK DESIGN SOLUTIONS
14451 Chambers Road, Suite 210
Tustin, CA 92780
Tel (949) 417-3903 x 103

ELECTRICAL ENGINEER
A & F ENGINEERING GROUP, INC.
9320 Baseline Rd. Suite C
Rancho Cucamonga, CA 91730
Tel (909) 941-3008

OWNER
LEAH SCHOELLER
CASp #862
Rancho Santiago Community College District
2323 North Broadway Suite 112
Santa Ana, CA 92706
Tel (657) 266-6480

NO.	DATE	DESCRIPTION
01	4/22/21	100% SD
02	6/18/21	60% CD
03	8/23/21	100% CD
04	10/18/21	DSA SUBMITTAL
05	5/5/22	ADDENDUM 1

THE ARCHITECT DOES NOT REPRESENT THAT THESE PLANS OR THE SPECIFICATIONS ARE SUITABLE FOR ANY SITE OTHER THAN THE ONE FOR WHICH THEY WERE SPECIFICALLY PREPARED. THE ARCHITECT DISCLAIMS RESPONSIBILITY FOR THESE PLANS AND SPECIFICATIONS IF THEY ARE USED IN WHOLE OR IN PART AT ANY OTHER SITE.

PROJECT OWNER & TITLE:
RANCHO SANTIAGO COMMUNITY COLLEGE DISTRICT
2323 NORTH BROADWAY,
SUITE # 112, SANTA ANA, CA 92706

BARRIER REMOVAL - BUILDING D MULTI-USER RESTROOMS RENOVATION

8045 EAST CHAPMAN AVE
ORANGE, CA 92869

SHEET TITLE
FIXTURE AND ACCESSORY DETAILS

DRAWN BY: SHEET NO. JOB NUMBER: 20110.01

A-900

DATE: OCTOBER 18, 2021

RFI # 6

PRE-BID CLARIFICATION FORM

(Email this completed form to FacilitiesBid@rsccd.edu. See Instructions to Bidders.)

PROJECT NAME:	Barrier Removal Building D Multi-user and Single-user Restrooms Renovation at Santiago Canyon College		
PROJECT NUMBER:	2742	BID NUMBER:	1419
EMAIL TO: facilitiesbid@rsccd.edu			
DATE:	4/18/22		
FROM:	Golden Gate Construction	EMAIL:	davis.goldengate@gmail.com; sunny.goldengate@gmail.com;
SPEC SECTION:		DRAWING NUMBER:	
REQUESTED CLARIFICATION:			
7) The Project NIB stated that this project was in accordance with CUPCCAA per para. 6; however, CUPCCAA projects, under public school projects, were less than \$200,000.00 value. Please confirm that the project value would be less than \$200,000.00? And will be rejected if the bid proposal is more than \$200,000.00?			
RESPONSE TO CLARIFICATION:			
The project estimated value is noted on RFI # 1 response. Responded to by RSCCD.			

Attach additional numbered sheets as necessary; however, only one (1) request shall be contained on each submitted form.

END OF DOCUMENT

Construction Phasing Plan - CPP#1

Attachment for item No. AD 1-1, Addendum #1, May 4, 2022

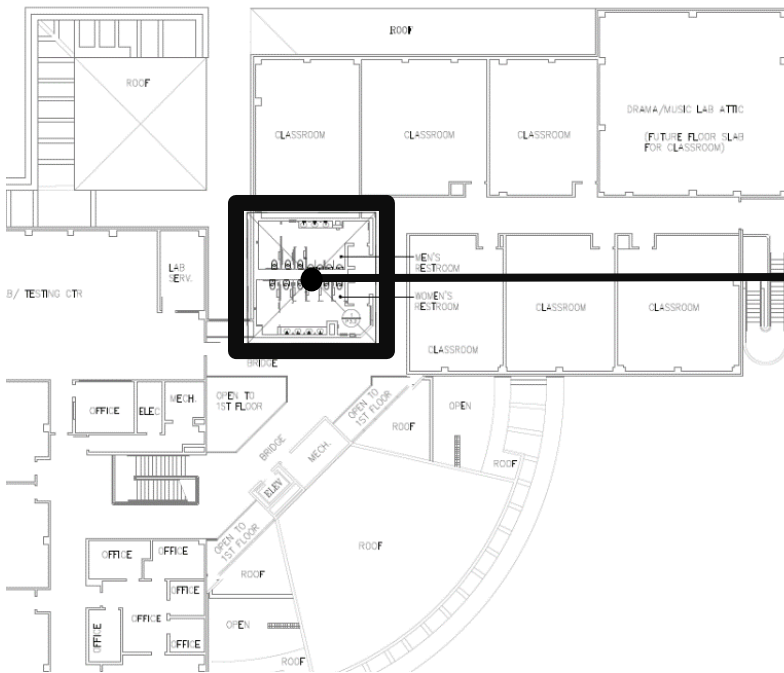

Phase 1: Building D, Second Floor Multi-user Restrooms

Notes for Phase 1:

The contractor shall not occupy the project site areas before September 5, 2022.
No construction or demolition work shall occur before September 5, 2022.



Phase 2: Building D, First Floor Multi-user and Single-user Restrooms

Temporary Partition Plan – TPP#1

Attachment for Item No. AD 1-2, Addendum #1, May 4, 2022

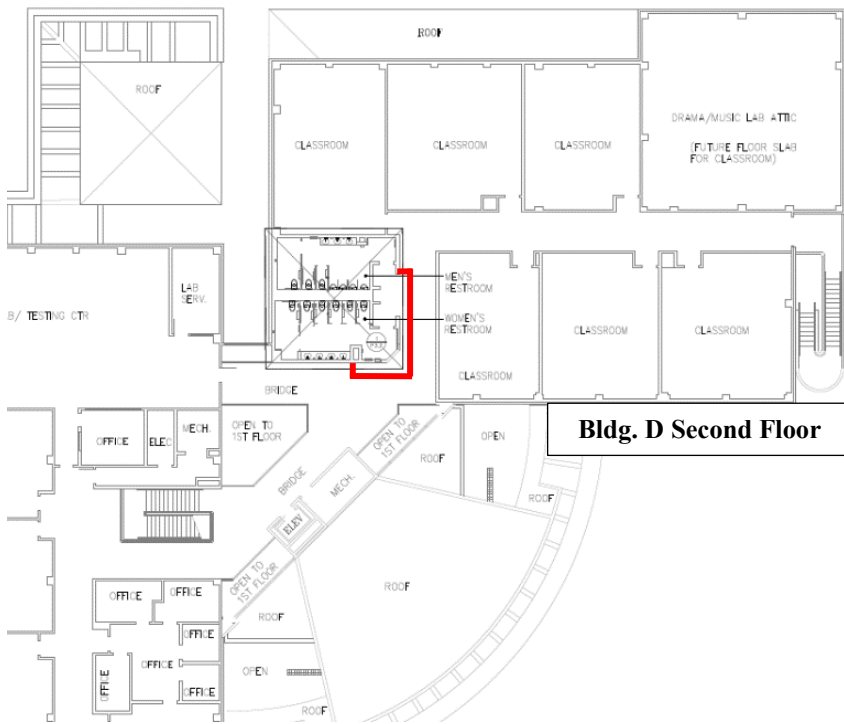

Notes:

 Full Height Temporary Partition

Provide full height temporary partitions enclosing the restroom entrances as indicated on temporary partition plan, prior to start of demolition and construction activities

- Temporary construction swing out door with lock. Coordinate and confirm exact location with District
- White painted plywood facing the hallway side
- Full height wall pinned to floor
- Bracing for support
- Repair existing walls, floor, and ceilings after removal
- Provide protective floor covering in hallway and sticky floor mats in front of all partition doors and all affected areas
- Keep existing hallway accessible at all times
- Post construction safety signs on partition wall, facing hallway
- Clean and patch damaged existing surfaces

Construction Staging Plan – CSP#1

Attachment for Item No. AD 1-3, Addendum #1, May 4, 2022

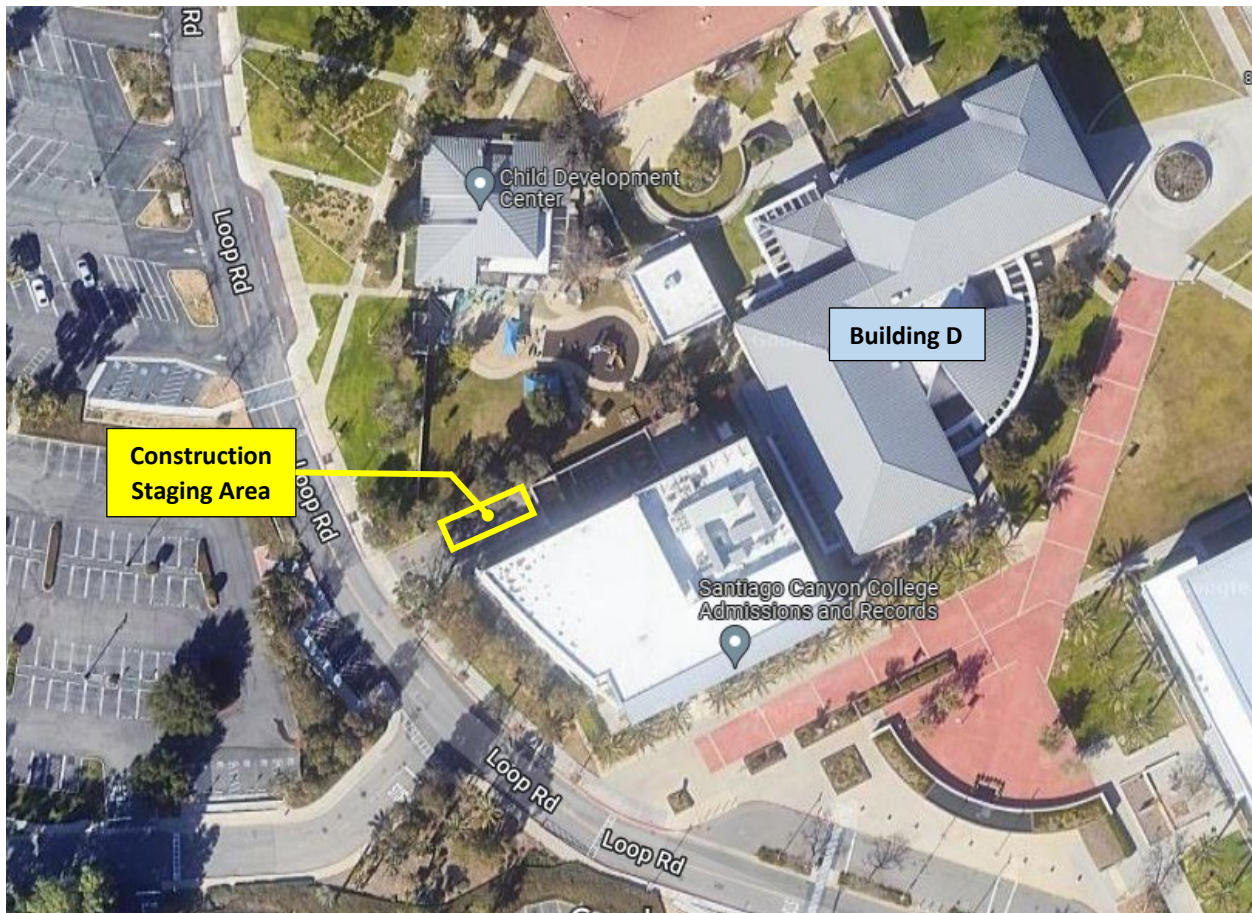

Notes for Construction Staging Plan:

1. Provide portable, full height fencing with screens to enclose the entire staging area prior to start of demolition.
2. Provide uninterrupted clearance to existing building double doors
3. Provide double, swing-out doors and construction signage.
4. Protect existing pavement used as construction staging area.